

Job Customer:

Title:

Ref:

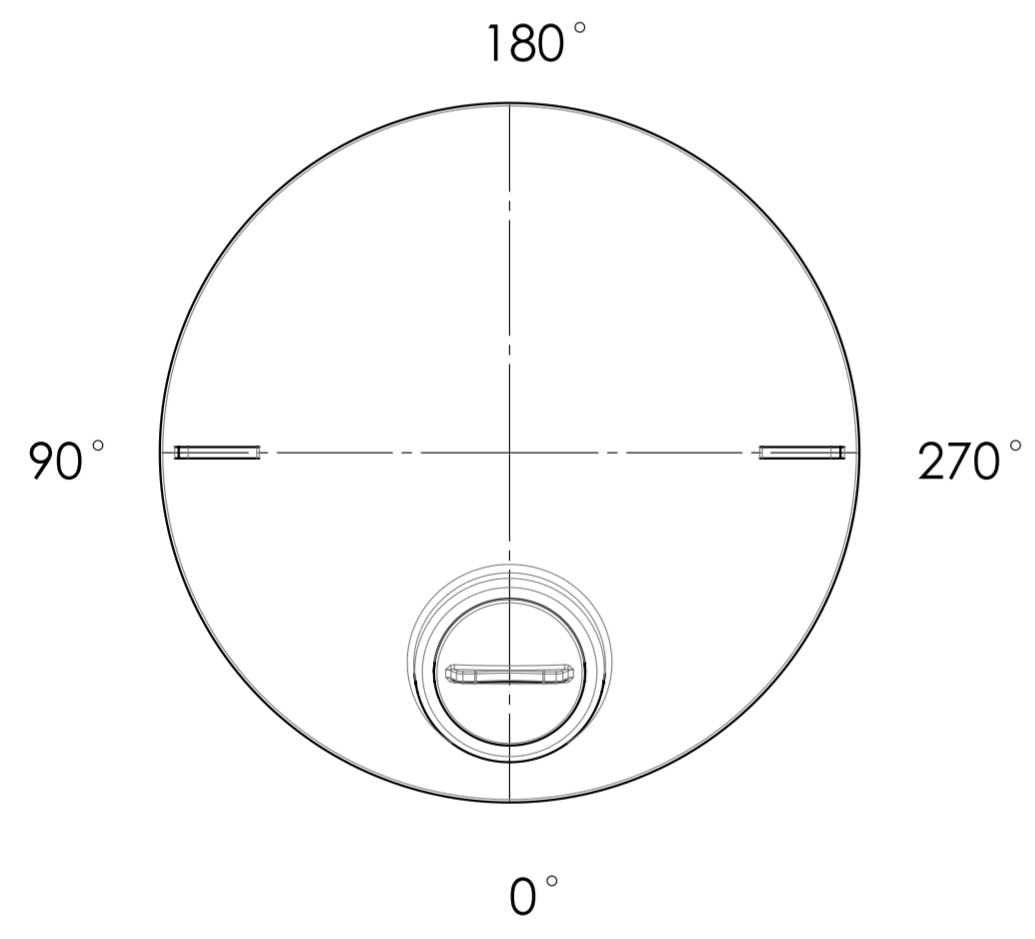
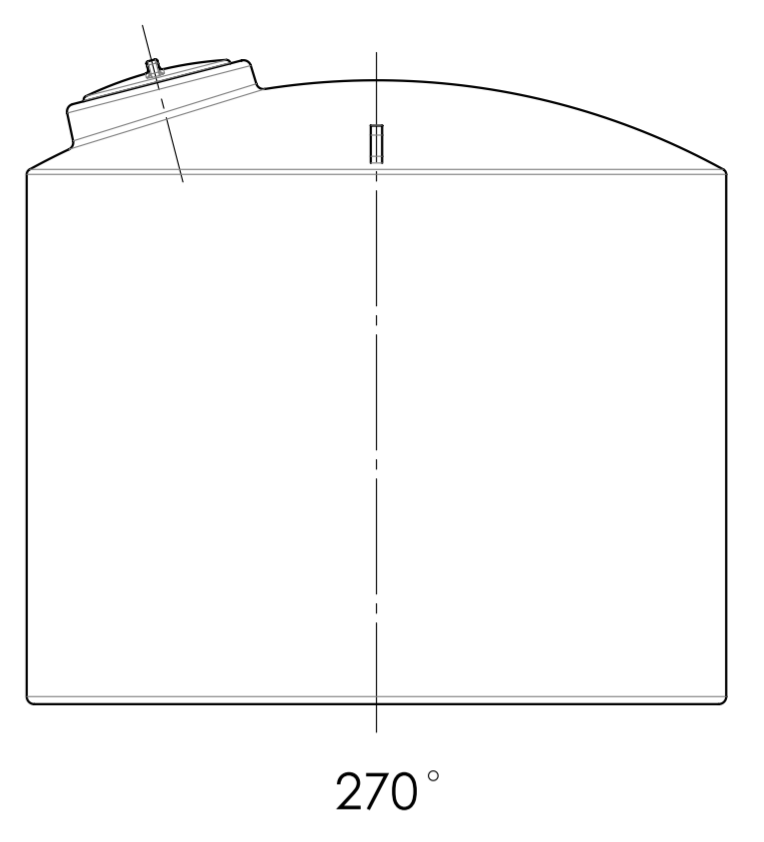
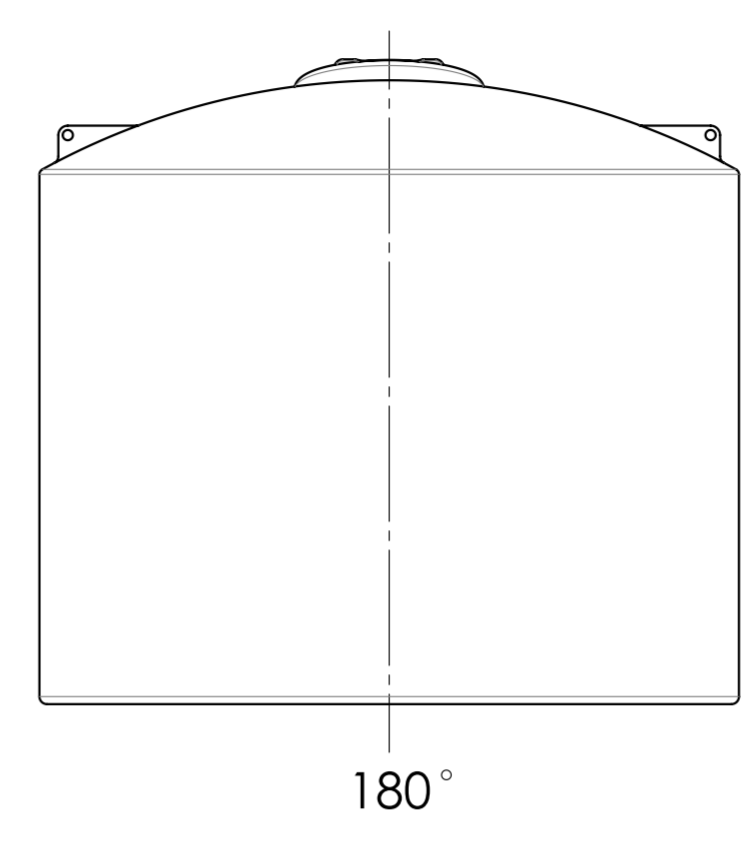
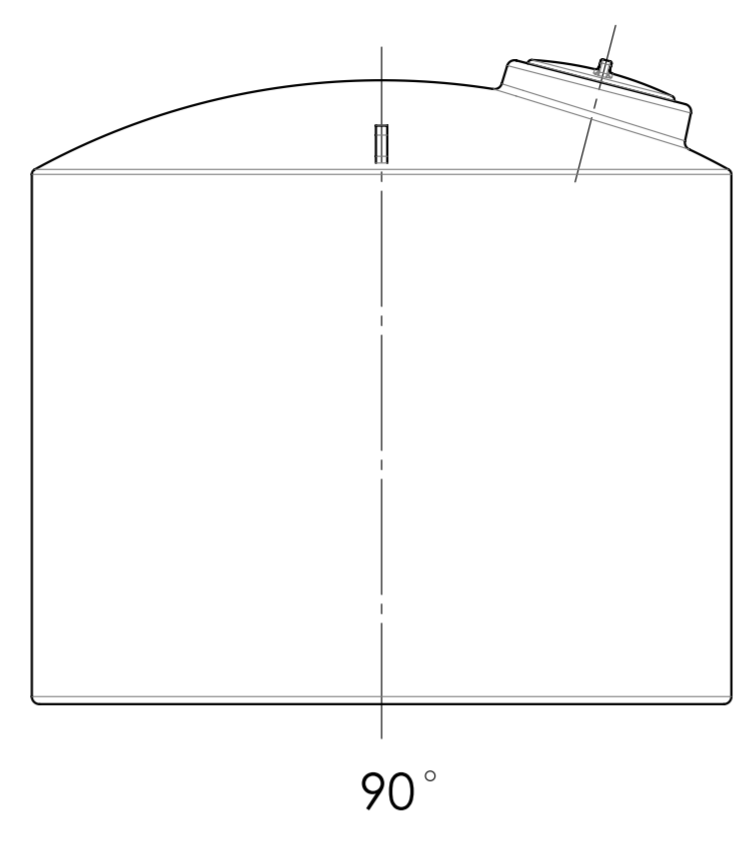
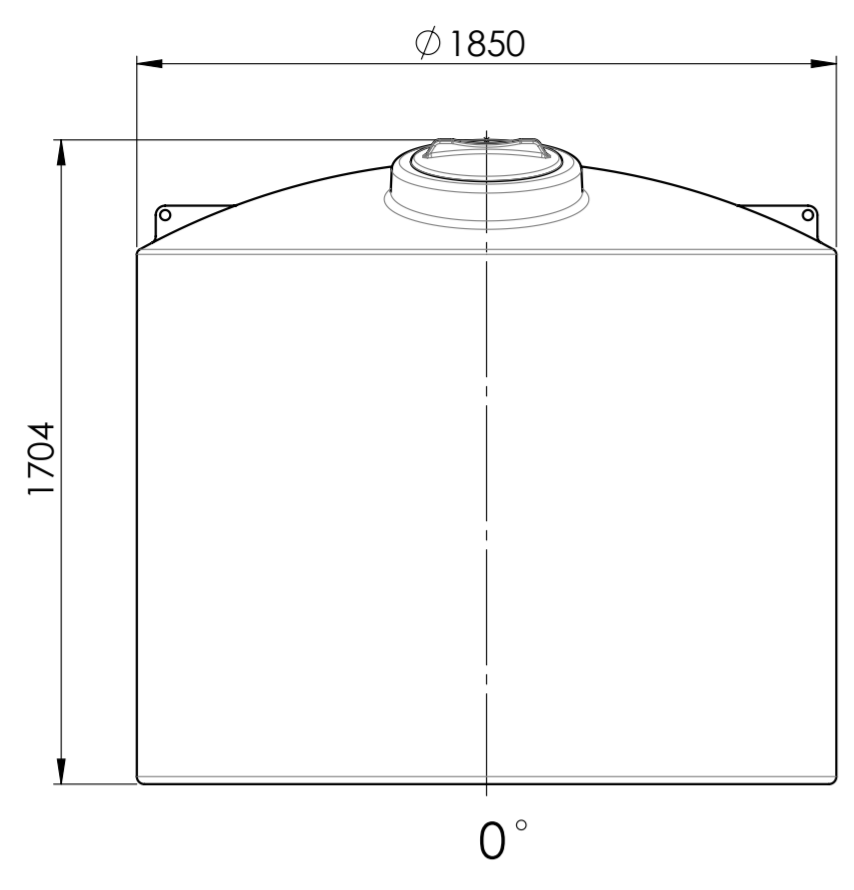

FITTINGS LAYOUT TABLE

NOZZLE No	PE SIZE	LEVEL MARK	ANGLE	DESCRIPTION
N1				
N2				
N3				
N4				
N5				
N6				
N7				

NOTES:

UNLESS OTHERWISE SPECIFIED: DIMENSIONS ARE IN MILLIMETERS		FINISH:		DEBURR AND BREAK SHARP EDGES		DO NOT SCALE DRAWING		REVISION	
TOLERANCES: LINEAR: ANGULAR:						 ENGINEERED PLASTICS		TITLE: 3500L XPRESS TANK (XPST03500) NOZZLES LAYOUT	
NAME	SIGNATURE	DATE						DWG NO.	A2
DRAWN									
CHK'D									
APPV'D									
MFG									
Q.A.						MATERIAL:			
						WEIGHT:		SCALE: 1:20	SHEET 1 OF 1